

WE MAKE RIDERS

CHICOUTIMI, QUÉBEC



TECHNICAL MANUAL

TROY 2025+

DEVINCI



ABOUT OUR MANUALS

Like many sports, cycling involves risk of injury and accidents, so you must be fully aware of these risks. Neither the manufacturer, the retailer, nor the person who sold you the bike, nor the people who maintain the trails are responsible for these risks. As you are solely responsible, it is, therefore, essential that you read and fully understand all the parts contained in this manual.

To enjoy maximum safety and enjoyment right from the get go, it is important that you are familiar with your new bike, its handling and its possibilities. It is your duty to maintain your bike well and reduce the risk of injury. Biking can be a dangerous activity, even under the best conditions. These are risks associated with using a bicycle that cannot be predicted or avoided. These are the sole responsibility of the cyclist.

YOUR AUTHORIZED DEVINCI RETAILER

Your authorized Devinci retailer is at your service to guide your choices of bike and accessories which are best suited to the style of biking you wish to perform. This will help you maintain your equipment in good condition so that you can take full advantage of your investment. The staff at your authorized Devinci retailer have the training, experience and tools to carry out the repairs and provide you with reliable advice.

However, your authorized Devinci retailer cannot make decisions for you, and cannot be held responsible for your lack of knowledge, experience, qualification or common sense. However, it will take the necessary time to explain the operation of a component or to help you choose an accessory that meets your specific needs.

For further information, please see the Devinci's User Manual available on www.Devinci.com or ask your authorized Devinci retailer. He will take the time to answer any questions you may have and will advise you with great pleasure.



FRAME: TECHNICAL SPECIFICATIONS **4**



CABLE ROUTING **8**

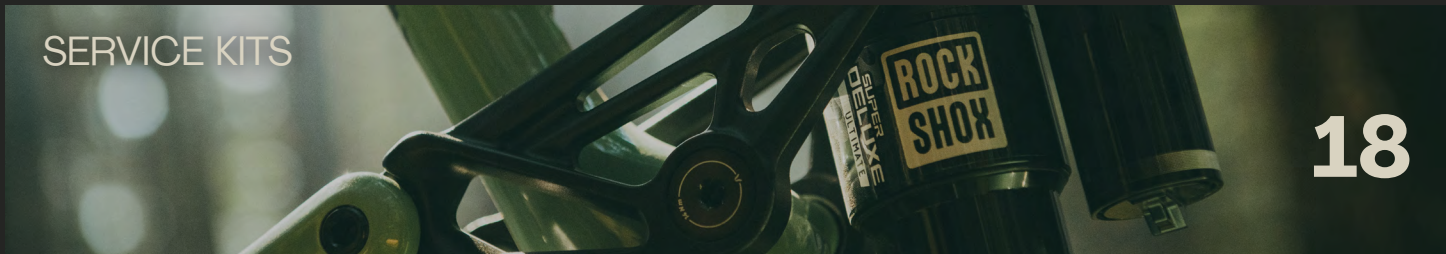

SERVICE KITS **18**



DEVINCI'S RIDE IN PEACE WARRANTY **28**

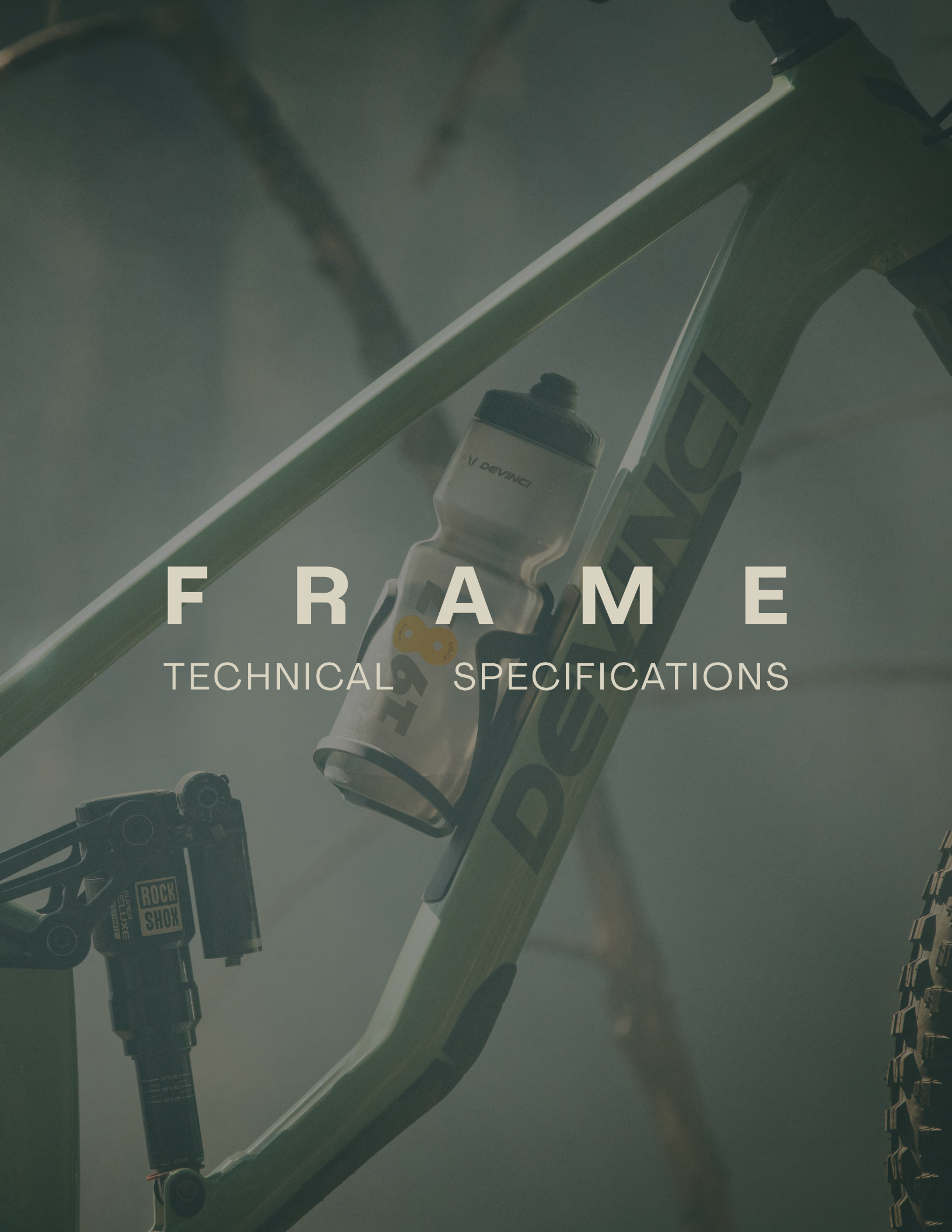

F R A M E

TECHNICAL SPECIFICATIONS



FORK TRAVEL ALTERATION

The Devinci Troy Gen-5 is specifically designed and tested for use with a 160 mm travel front suspension fork. Any modifications to the fork travel or style, including but not limited to a 170 mm travel fork, are not recommended and will void the original frame warranty.

The maximum allowable axle-to-crown length for the Devinci Troy Gen-5 is 576 mm. Exceeding this measurement may compromise the bike's performance and safety, potentially leading to catastrophic frame failure and serious personal injury.

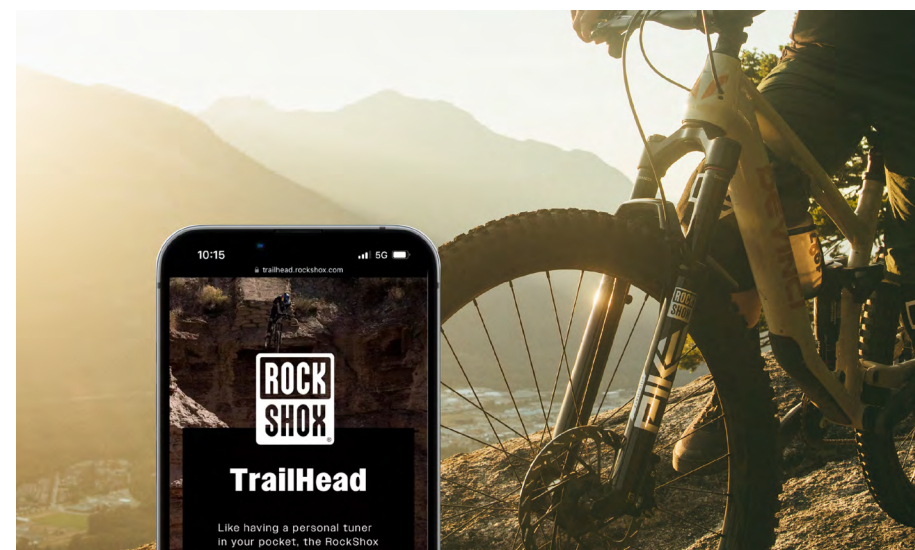

SUSPENSION SET UP

Suspension specialist in your pocket!

The RockShox TrailHead app is a starting point for dialing in your suspension settings, ensuring a perfect ride experience.

WEB: [GET STARTED](#)

APPLE STORE: [DOWNLOAD THE APP](#)

GOOGLE STORE: [DOWNLOAD THE APP](#)

HEADTUBE DIMENSIONS		
1. UPPER (S.H.I.S)	ZS44	1-1/8" Zerostack
2. LOWER (S.H.I.S)	ZS56	1.5" Zerostack
BOTTOM BRACKET		
3. STANDARD	BSA 73	
4. ISCG MOUNT	ISCG 05 3 tabs	
5. MINIMUM Q FACTOR	168	
MECHANICAL DRIVETRAIN		
6. REAR HUB SPACING (OVER LOCKNUT DIMENSION)	TA 12x148 Boost	
7. MAX & MIN CHAINRING	34T	28T
8. SMALLEST COG COMPATIBLE	12s 9T	
9. BIGGEST COG COMPATIBLE	12s 52T	
10. RECOMMENDED CHAINLINE	55mm	
SEATPOST & SEATCLAMP		
11. SEAT TUBE INSIDE DIAMETER (ID)	31.6 mm	
12. SEAT TUBE OUTSIDE DIAMETER (OD)	35 mm	
13. DROPPER POST COMPATIBLE	YES Fully internal	
BRAKES		
14. BRAKE MOUNT (FRAME)	Post-Mount 200 mm direct	
15. MAX ROTOR SIZE AVAILABLE (FRAME)	220 mm	
ACCESSORIES		
16. WATER BOTTLE (FRAME)	YES (16 OZ.)	
17. STORAGE SYSTEM	YES SHED	
18. PROTECTORS	DOWNTUBE & CHAINSTAY	
GEOMETRY INPUTS (BASED ON MEDIUM SIZE)		
TROY FORK 160 MM TRAVEL 150MM		
19. FRONT SUSPENSION (TRAVEL & SAG)	160 mm	20-25%
20. REAR SUSPENSION (TRAVEL & SAG)	150 mm	30%
21. FORK (AXLE-TO-CROWN [A] & OFFSET [B])	A. 571	B. 44
22. FRONT & REAR WHEEL GEOMETRY	750	
23. FRONT & REAR WHEEL MAX ETRTO	63-622	63-622
24. REAR SUSPENSION (DIMENSIONS & SAG)	185 x 55 mm	30%
25. PIGGYBACK SHOCK COMPATIBILITY	YES	
26. SPRING TYPE COMPATIBILITY	Air & Coil	
27. REAR SHOCK ORIENTATION	FORWARD UP	
28. UPPER (OR FRONT) SHOCK HARDWARE DIMENSION	Trunnion	
29. LOWER (OR REAR) SHOCK HARDWARE DIMENSION	40 x 10 mm	
30. REAR TIRE CLEARANCE*	27,5" x 2,6" 29" x 2,5"	

* **DISCLAIMER:** We are testing many different tires to establish a clearance number that cover a wide spectrum of tires with appropriate frame clearance. However, it is impossible for us to test all tires and rim combination available on the market, so be mindful that some combinations may result in slight rubbing if higher than 66mm in actual width.

SIZES AVAILABLE
S | M | L | XL



13 MAX INSERTION LENGTH
S: 240mm
M: 280mm
L: 305mm
XL: 330mm

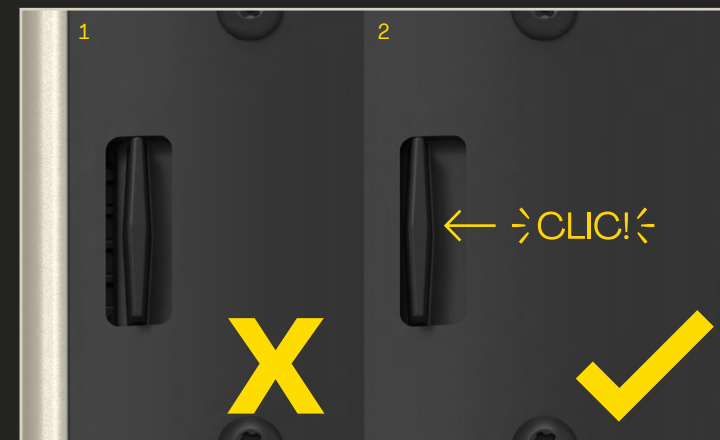

i THE STORAGE DOOR MUST BE PROPERLY ENGAGED TO ENSURE ITS ATTACHMENT AT THE DOWNTUBE LEVEL.

A "CLICK" WILL ACCOMPANY THE CLOSURE WHEN THE DOOR IS SECURELY LOCKED ONTO THE INNER SURFACE OF THE DOWNTUBE.

MAKE SURE THE LATCH IS CORRECTLY PRESSED BEFORE EACH RIDE (ACCORDING TO IMAGE 2).



CABLE ROUTING

CABLE ROUTING



BEFORE STARTING

SHIFT AND BRAKE HOUSING GUIDES

Make sure the guides are in place before you start routing the cables inside the frame. If they are not already in place, follow these steps before you begin:

- STEP 1** | *To orient the guide correctly through the downtube, take a 5mm housing and insert it into the guide.*
- STEP 2** | *Insert the guide with the housing inside through the opening at the bottom of the seat tube, above the bottom bracket.*
- STEP 3** | *Secure the outer part of the guide to the seat tube using the small screw to lock the guide's position on the frame. Repeat the steps for the other side.*

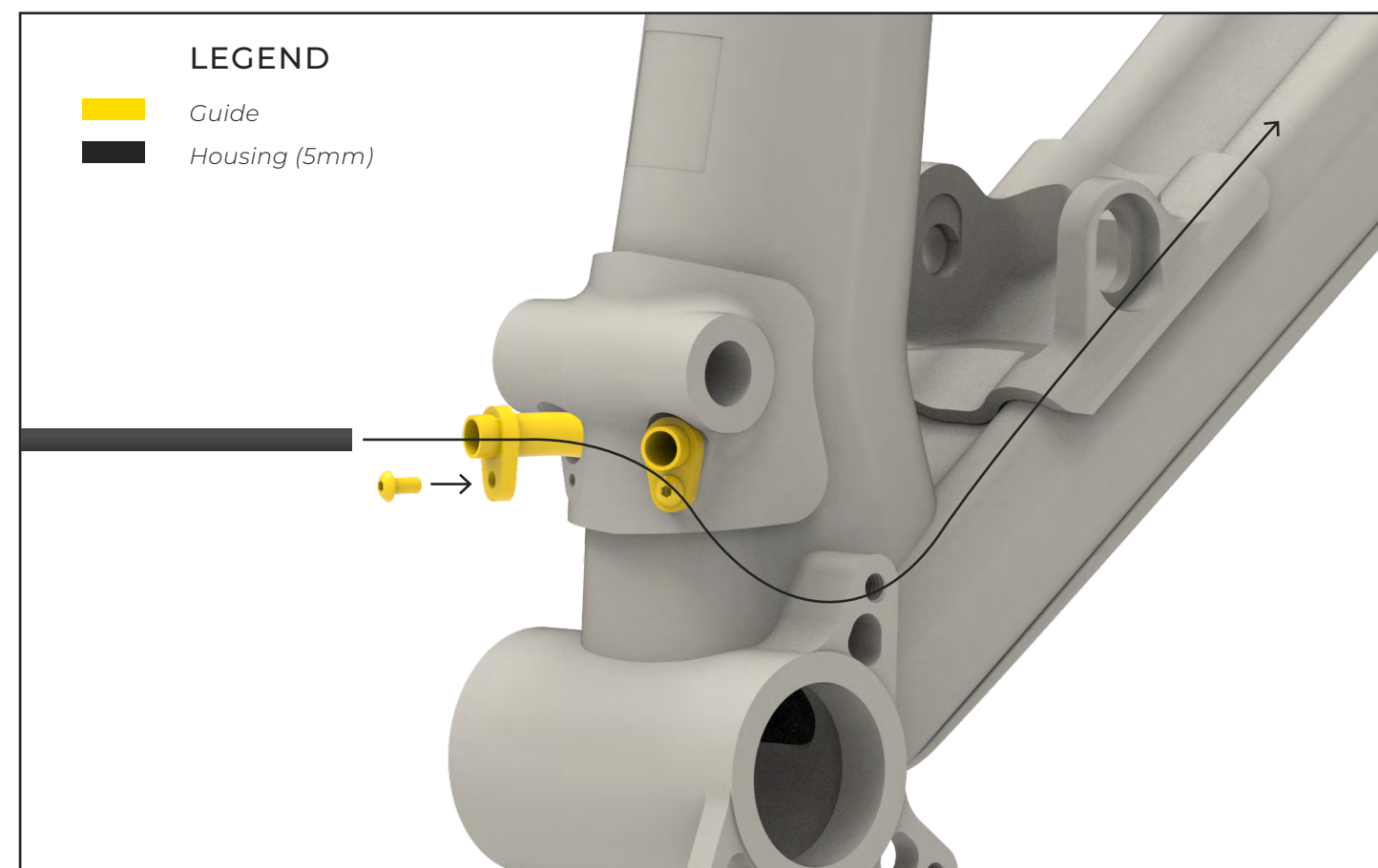

CABLE ROUTING

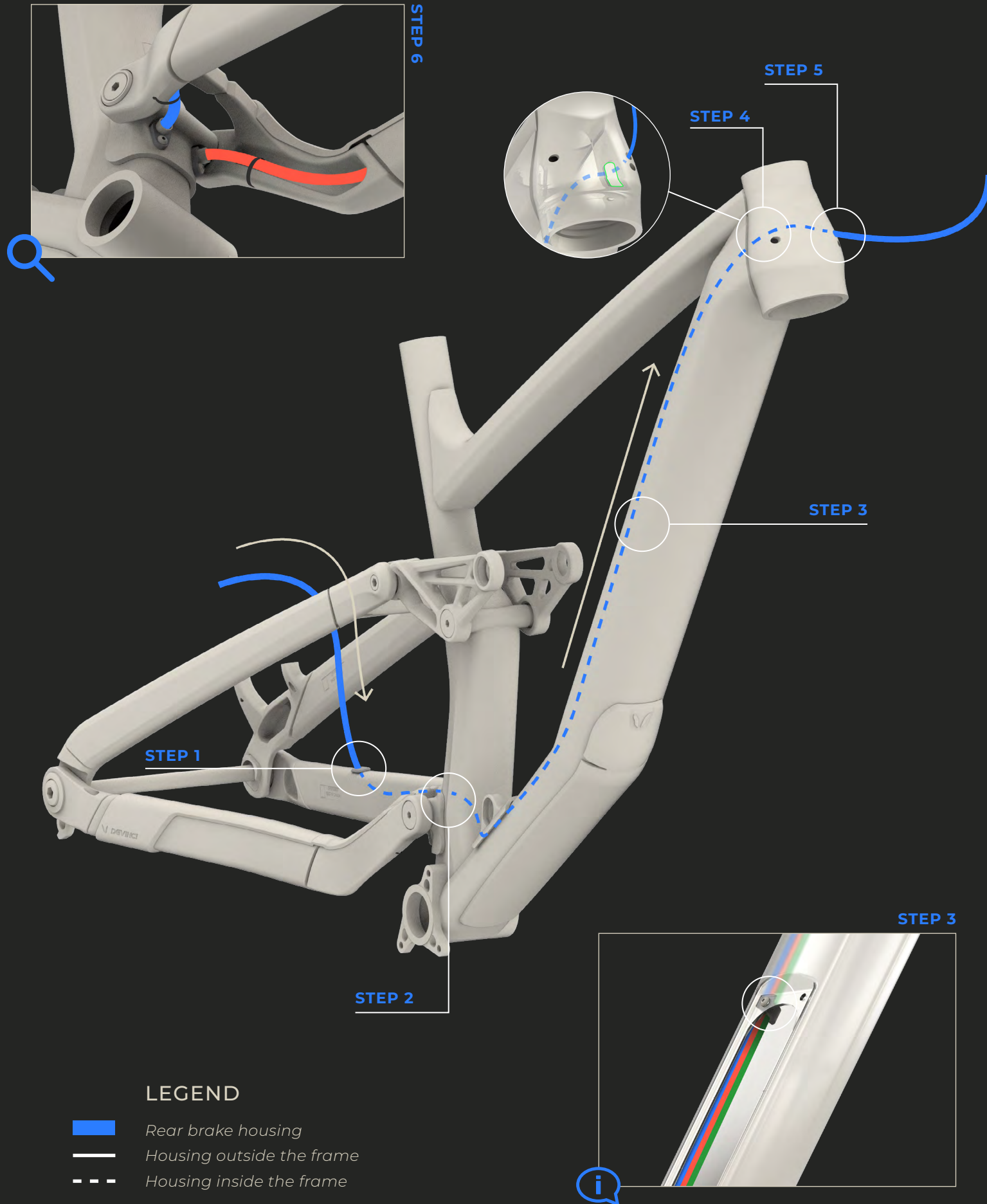

REAR BRAKE HOUSING

- STEP 1** | Introduce the rear brake housing through the rubber grommet located on the top of the base, on the left side, and route it to the opening at the front.
- STEP 2** | Insert the rear brake housing into the diagonal through the left guide located at the bottom of the seat tube.
- STEP 3** | Slide the housing on the left side into the diagonal until it reaches the head tube, securing it against the inner surface of the diagonal using the provided clips.
- STEP 4** | Insert the rear brake housing into the left inner oval opening of the head tube.
 - i** Ensure that the rear brake housing is properly inserted into the left inner cavity of the head tube to prevent rubbing against the fork's steerer tube.
- STEP 5** | Pull the housing out through the upper left opening located on the head tube.
- STEP 6** | Secure the rear brake housing at the chainstay in the designated spot using a small zip tie.
 - i** Make sure to properly complete the last step to avoid the risk of rubbing between the housing and the tire.

CABLE ROUTING

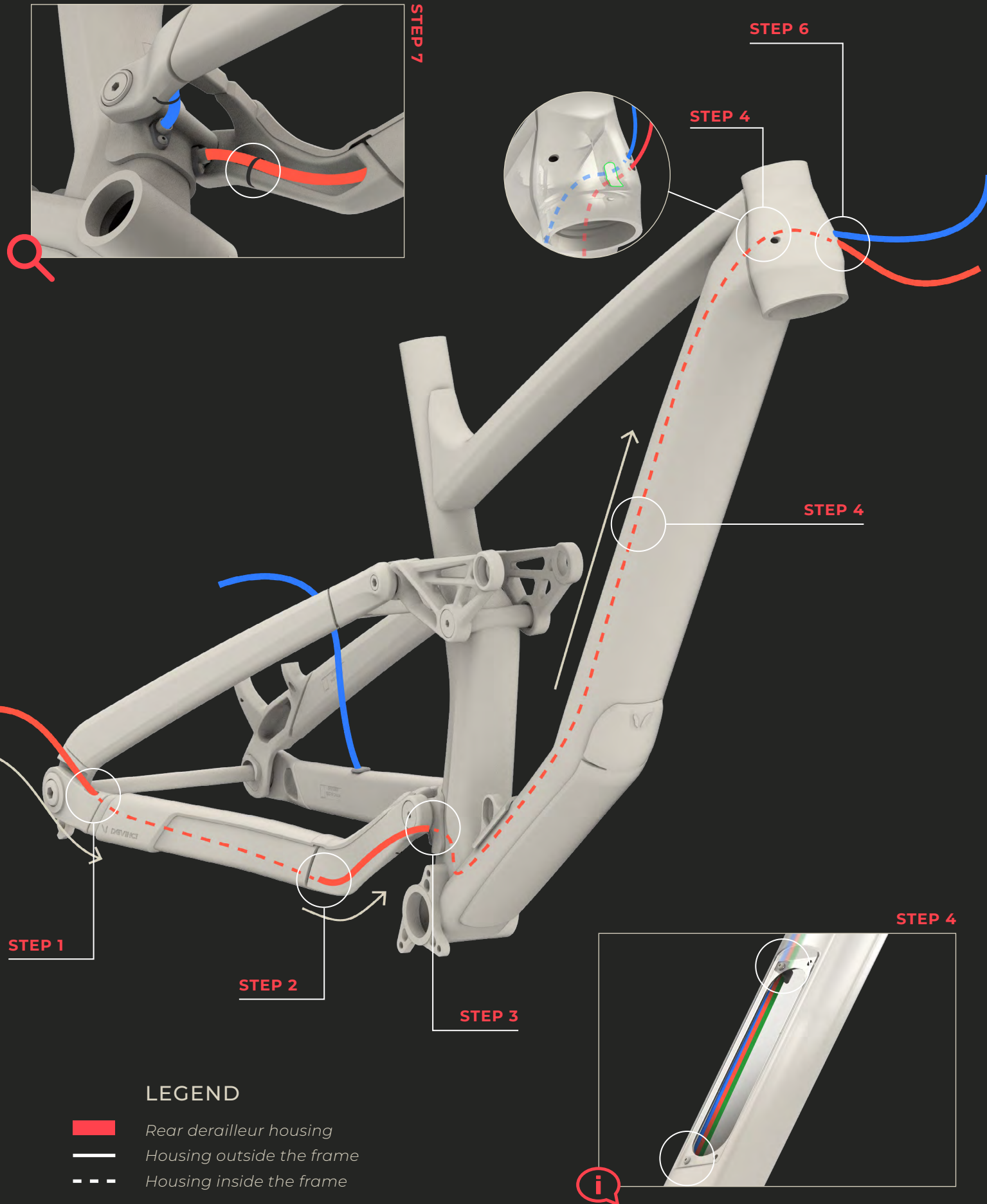

REAR DERAILLEUR HOUSING

i Tip → Slightly bend the end of the housing to facilitate its insertion into the base before starting.

STEP 1 | Insert the rear shift housing through the opening located on the upper surface of the base.

STEP 2 | Route the housing through the base on the right side and pull it out through the opening located on the inner surface at the front of the base.

STEP 3 | Insert the housing into the diagonal through the right guide located at the bottom of the seat tube.

STEP 4 | Slide the housing to the left into the diagonal until it reaches the head tube, securing it against the inner surface of the diagonal using the provided clips.

STEP 5 | Insert the rear brake housing into the left inner oval opening of the head tube.

i Ensure that the rear brake housing is properly inserted into the left inner cavity of the head tube to prevent rubbing against the fork's steerer tube.

STEP 5 | Pull the housing out through the lower left opening located at the front of the head tube.

STEP 6 | Secure the rear shift housing at the base in the designated spot using a small zip tie.

i Make sure to properly complete the last step to avoid the risk of rubbing between the housing and the tire.

CABLE ROUTING



SEAT POST HOUSING

STEP 1 | Insert the seat post housing into the head tube through the opening located on the right side.

STEP 2 | Insert the seat post housing into the right inner oval opening of the head tube.

i Ensure that the seat post housing is properly inserted into the right inner cavity of the head tube to prevent rubbing against the fork's steerer tube.

STEP 3 | Slide the housing to the left into the diagonal until it reaches the bottom bracket, securing it against the inner surface of the diagonal using the provided clips.

STEP 4 | Pull the housing out of the frame through the bottom bracket. Create a loop with the housing to facilitate its reinsertion.

STEP 5 | From the bottom bracket, insert the housing into the seat tube until it reaches the other end of the tube.

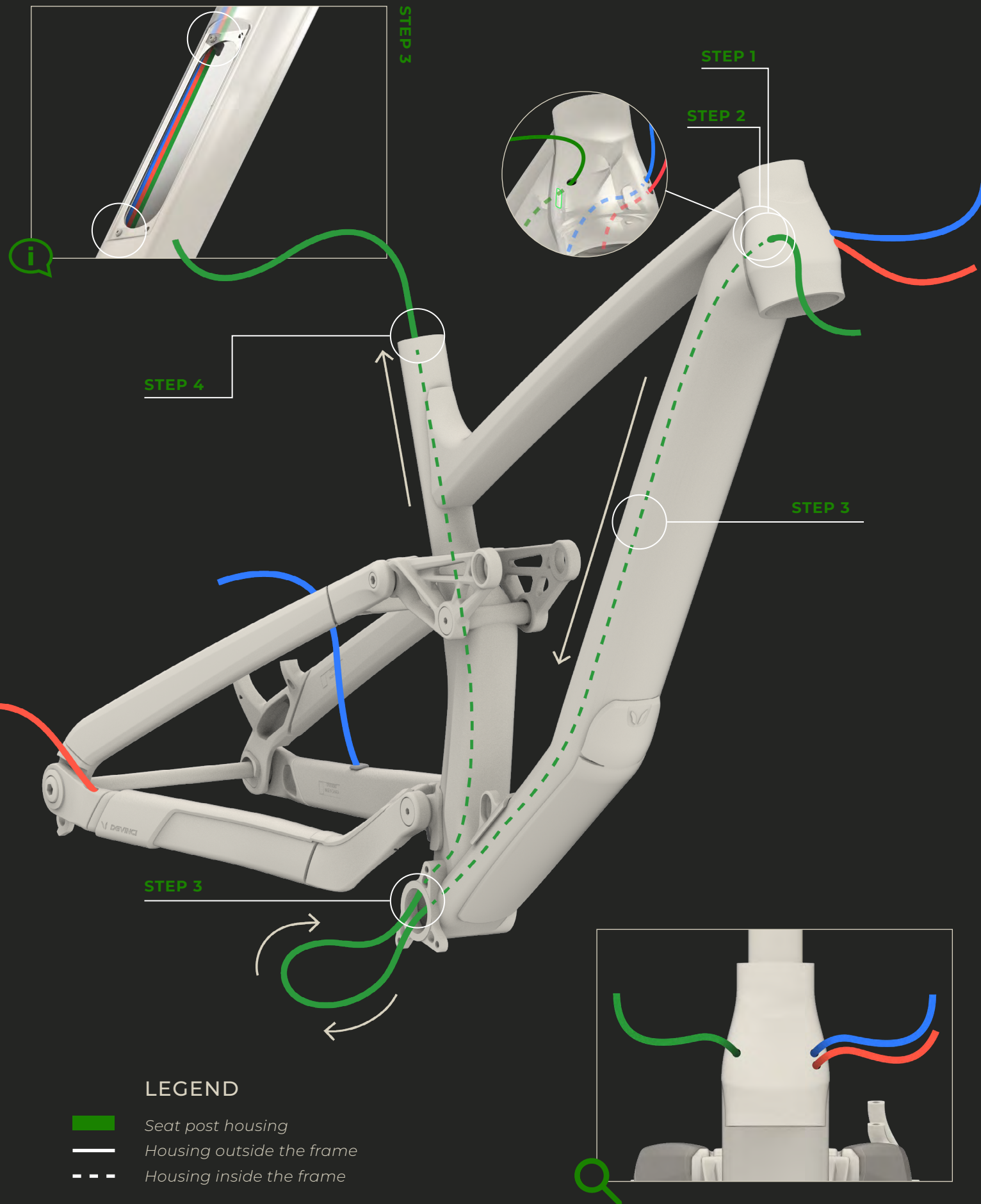





LEGEND

- Seat post housing
- Housing outside the frame
- Housing inside the frame



CABLE ROUTING OVERVIEW

LEGEND

-  Rear brake housing
-  Rear derailleur housing
-  Seat post housing
-  Routing outside the frame
-  Routing inside the frame

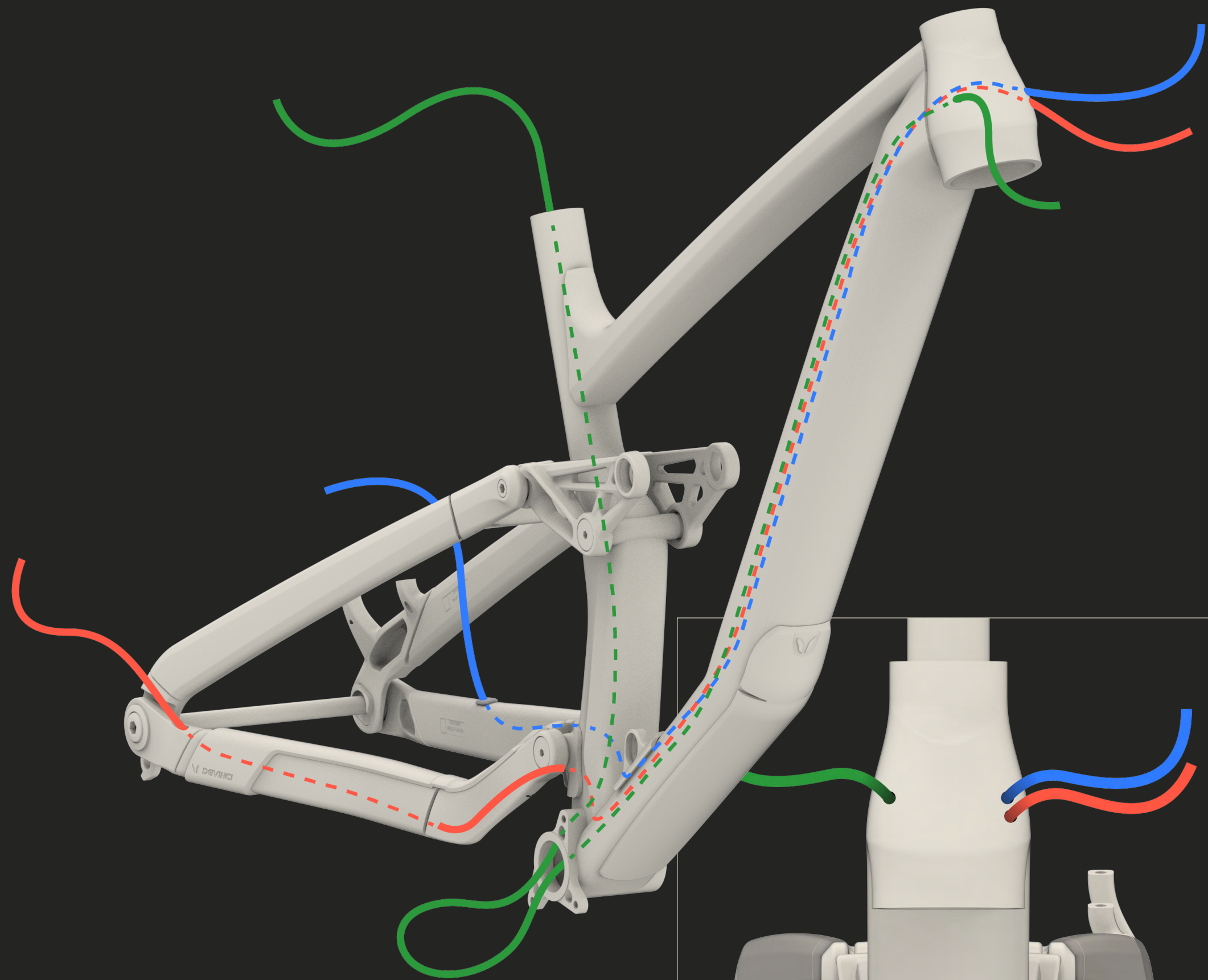

Ensure that the housings are parallel to each other to avoid interfering with the proper functioning of the housings and the smooth sliding of the bag inside the diagonal tube.



SERVICE KITS

KFC08902 | BALL BEARING KIT TROY/TROYST

ITEMS	PART #	DESCRIPTION	QTY
1	MFP21016	BALL BEARING MR20307 20x30x7; STD TYPE, DOUBLE LIP	2
2	MFP24014	BEARING 6900 WITH EXTENDED INNER CAGE	2
3	MFP19001	BALL BEARING 3801 LLU MAX 12x21x8	6

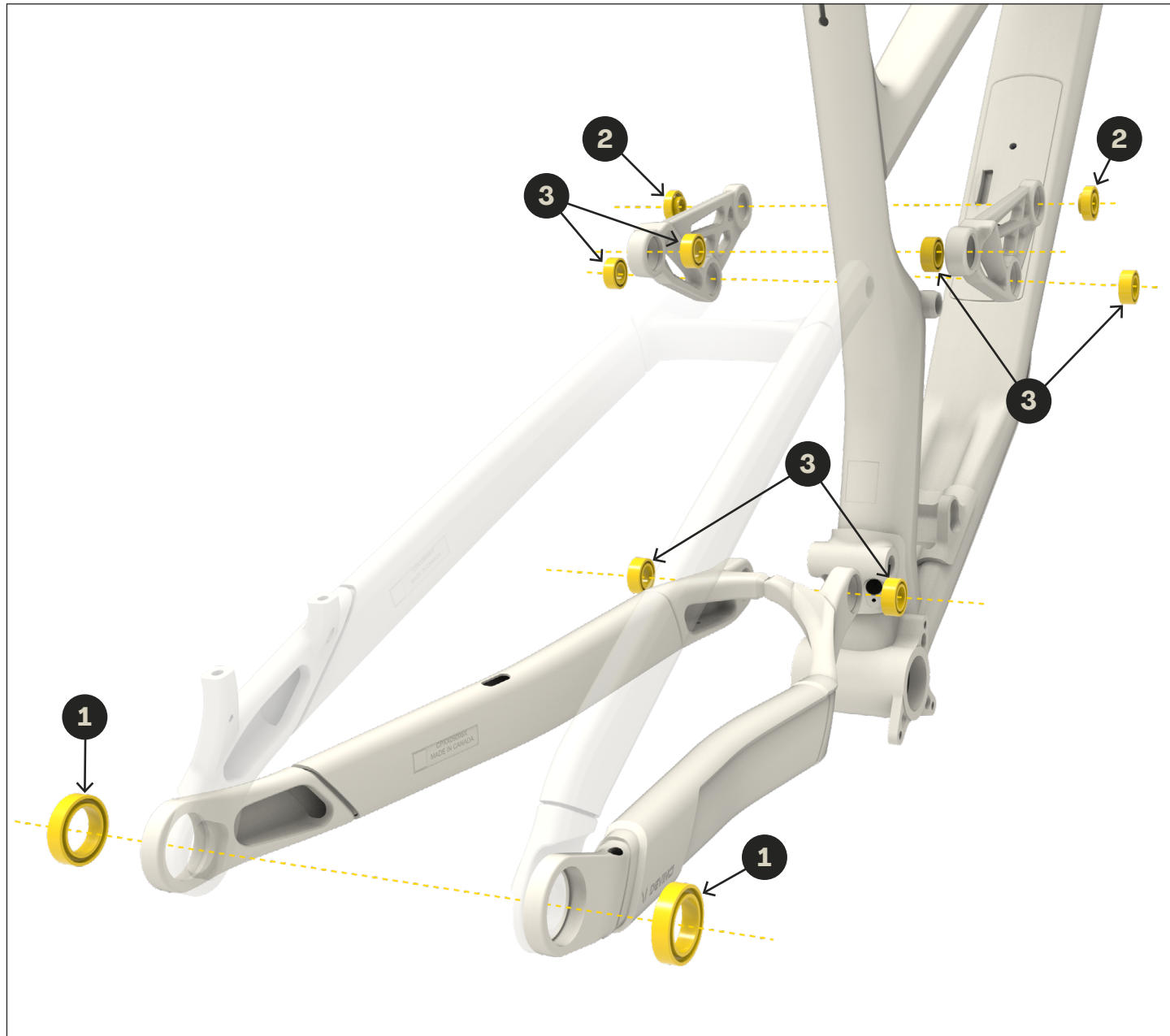

KFC09001 | SHOCK BOLT KIT TROY/TROYST

ITEMS	PART #	DESCRIPTION	QTY
1	MFV24009	SOCKET CAP SCREW M10x1.0 X 16mm	2
2	MFP25008	ADJUSTER 5.5mm FOR 10mm SCREW	1
3	MFP25009	ADJUSTER 5.5mm M10x1.0	1
4	MFV25001	SOCKET CAP SCREW M10x1.0 X 59	1

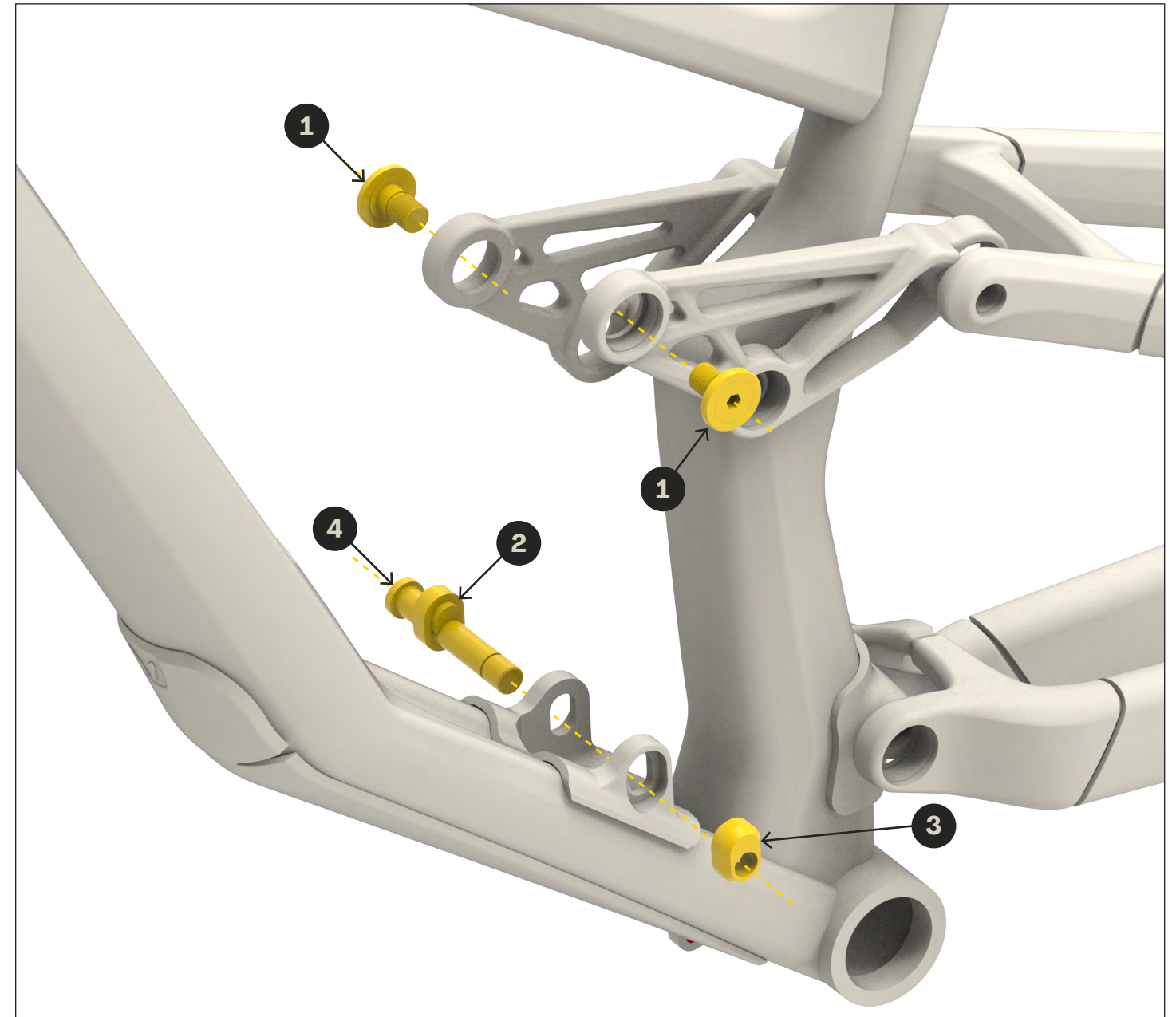

KFC09002 | PIVOT KIT TROY/TROYST

ITEMS	PART #	DESCRIPTION	QTY
1	MFP24008	Split pivot NDS shaft 20mm	1
2	MFD21001	HANGER UDH	1
3	MFP24009	Nut for 20mm split pivot shaft	1
4	MFV24016	Pivot screw M12 x1.0 x 21mm	2
5	MFV24008	Washer for pivot Emtb-SL	2
6	MFV24012	Socket flat screw M8x1.25 X 20mm, SS blk	2
7	MFP24010	Linkage Pivot shaft Emtb-SL	2
8	MFP24012	CS pivot spacer Emtb-SL	2

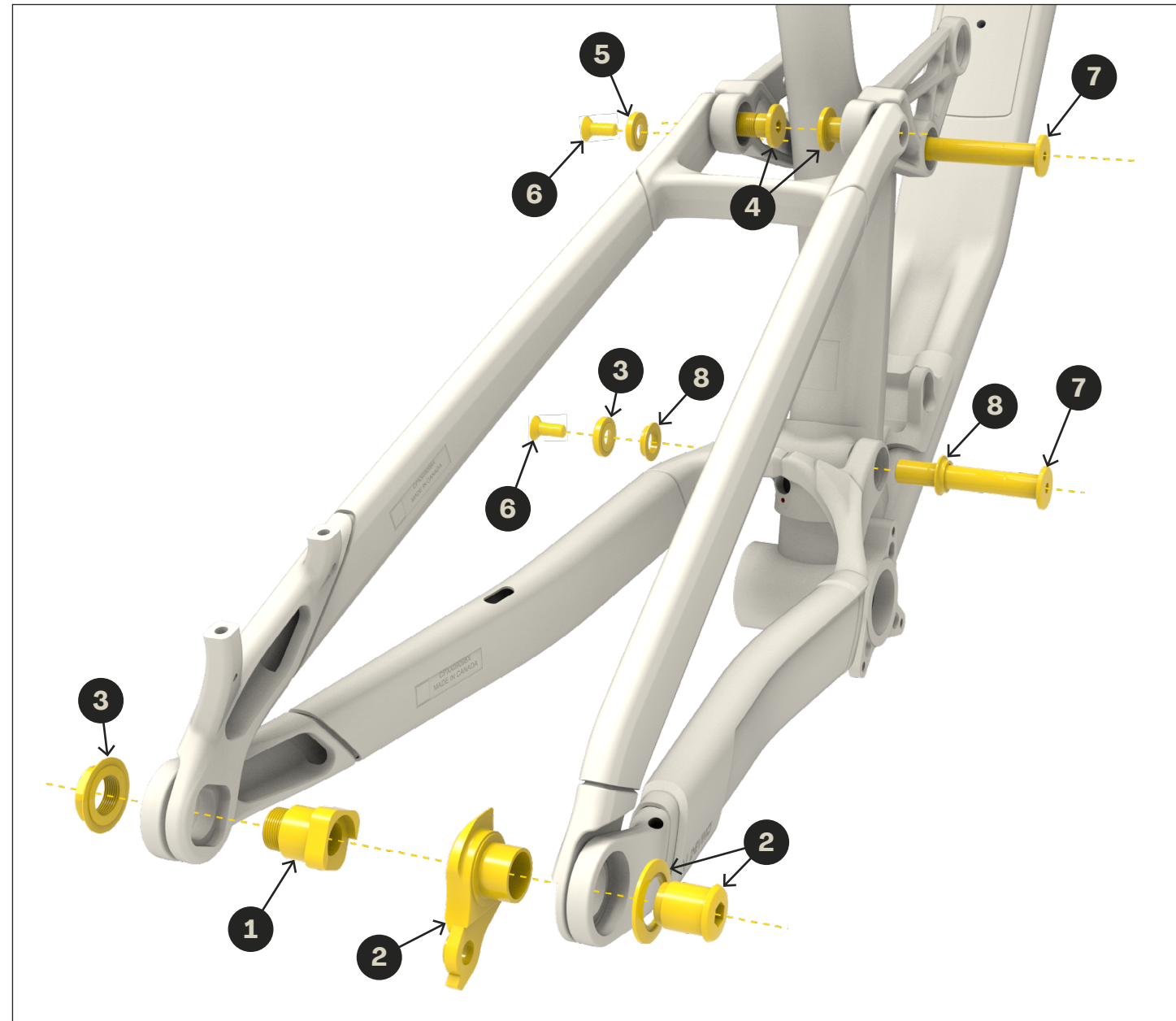

KFC09003 | CABLE GUIDE KIT TROY/TROYST



ITEMS	PART #	DESCRIPTION	QTY
1	MFB19008	CABLE GUIDE 5mm	1
2	MFB25001	CABLE GUIDE FOR 081-090	2
3	MFV23016	ALLEN BUTTON SCREW M3x0.5 X 6mm	2

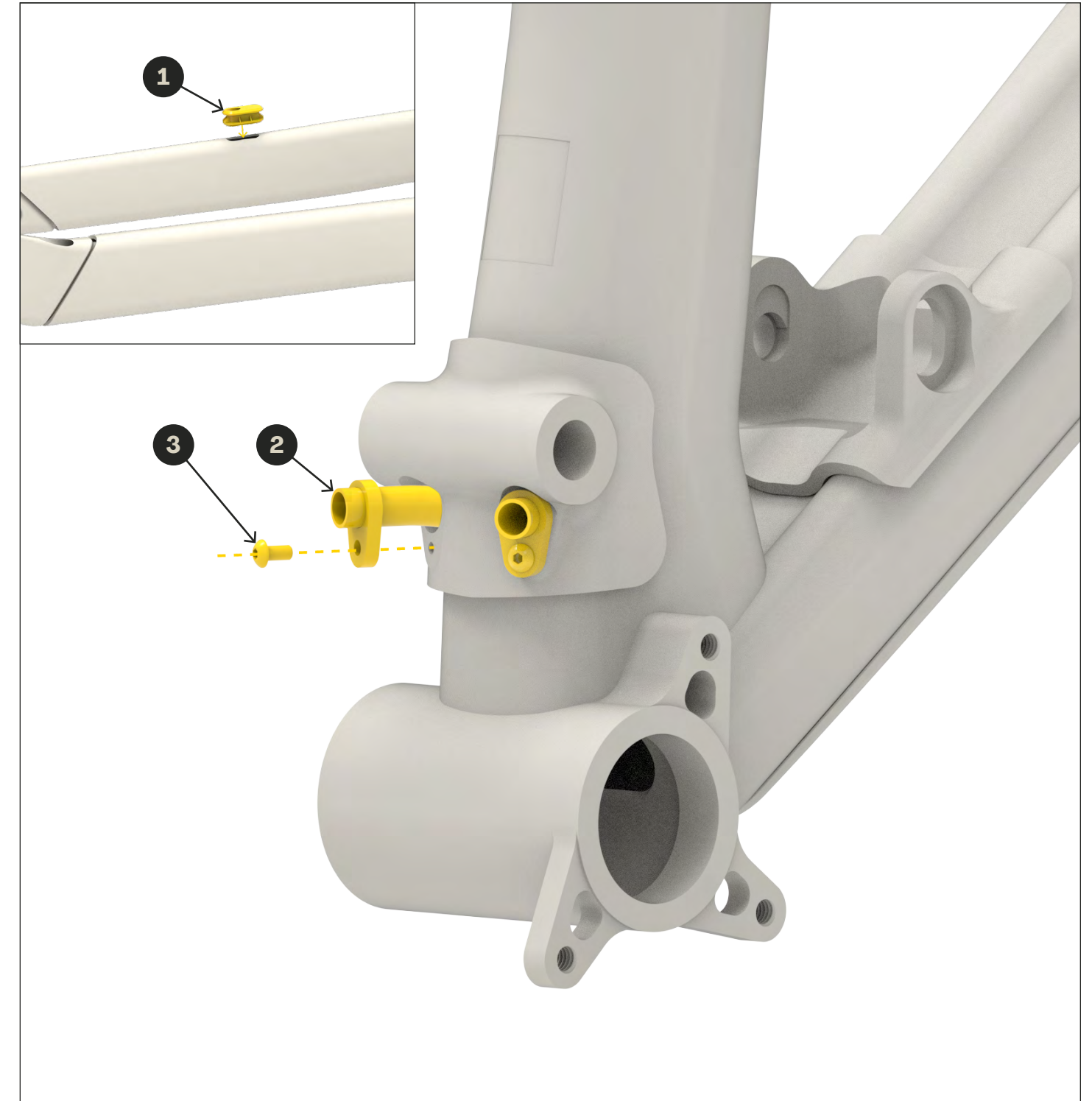

KFC09004 | CHAINSTAY PROTECTOR TROY/TROYST

ITEMS	PART #	DESCRIPTION	QTY
1	MACP25001	CHAINSTAY PROTECTOR 090-9800	1

KFC09005 | DOWN TUBE PROTECTOR TROY/TROYST

ITEMS	PART #	DESCRIPTION	QTY
2	MACP25002	DT PROTECTOR 081-090	1

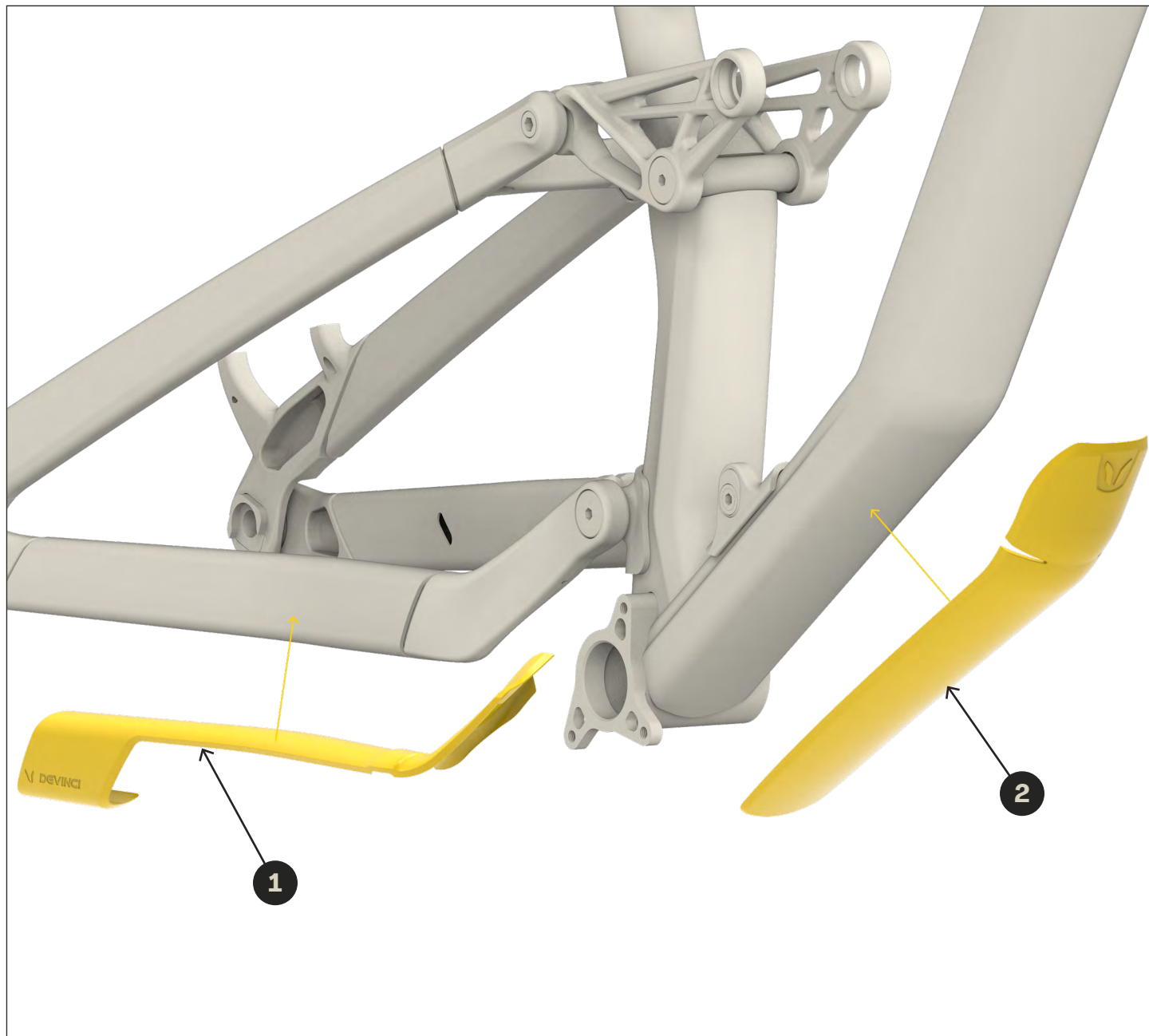

KFC09006 | 'SHED' STORAGE ASSEMBLY



ITEMS	PART #	DESCRIPTION	QTY
1	MPAC24001	PORTE DE RANGEMENT ASSEMBLÉE	1
1.1	MFP24027	SYSTEM DOOR	1
1.2	MFP24028	MECANISM COVER	1
1.3	MFP24029	SYSTEM LOCK	1
1.4	MFV097132	FLAT HEAD THREAD FORMING SCREW FOR PLASTIC, #4 X 3/8"	2
1.5	MFV07003-01	ALLEN BUTTON SCREW M5x0.8 X 12	2
1.6	MFP24030	SYSTEM SEAL	1

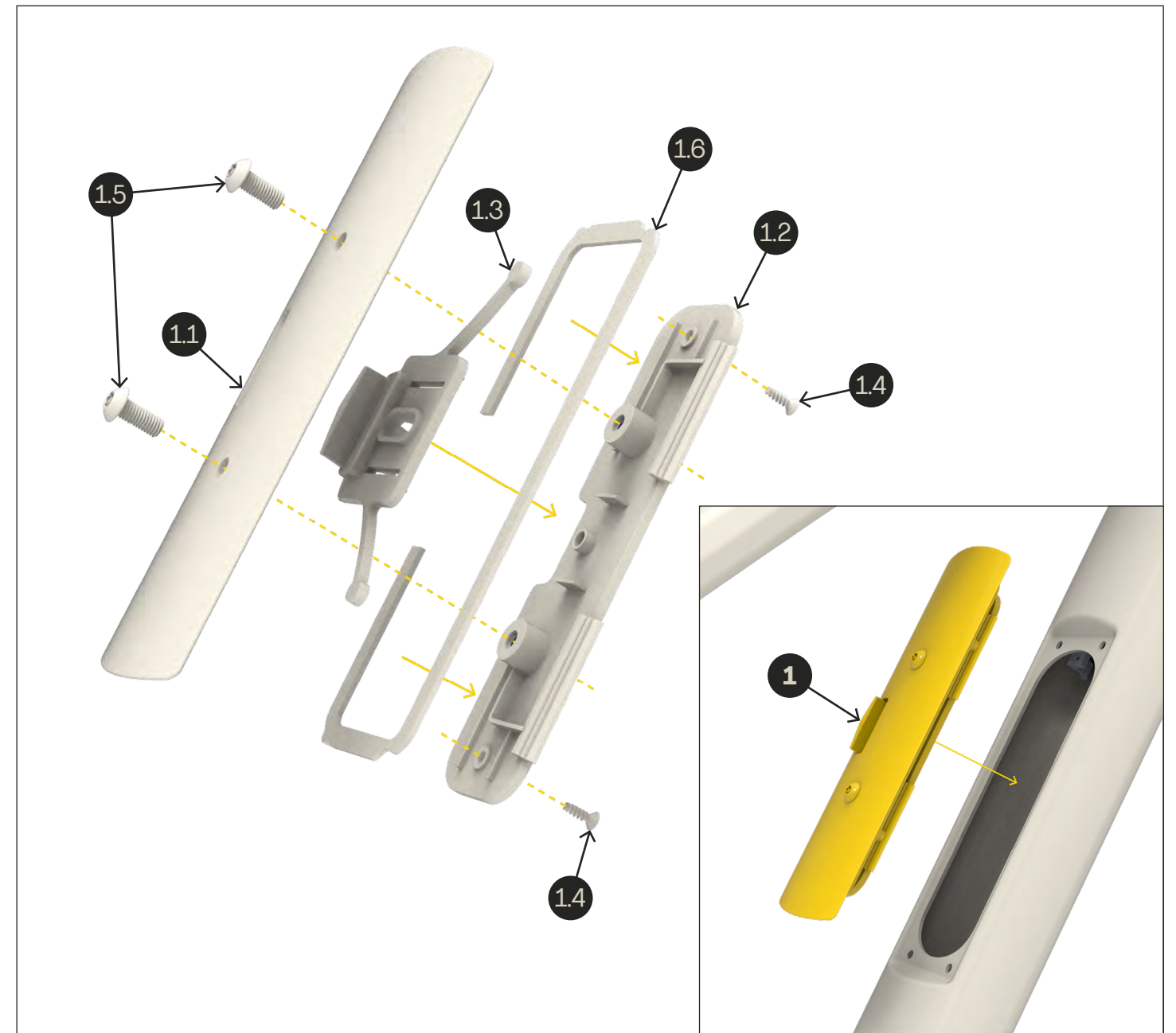

KFC05602 | DERAILLEUR HANGER UDH

ITEMS	PART #	DESCRIPTION	QTY
1	MFP21001	RD Hanger UDH	1

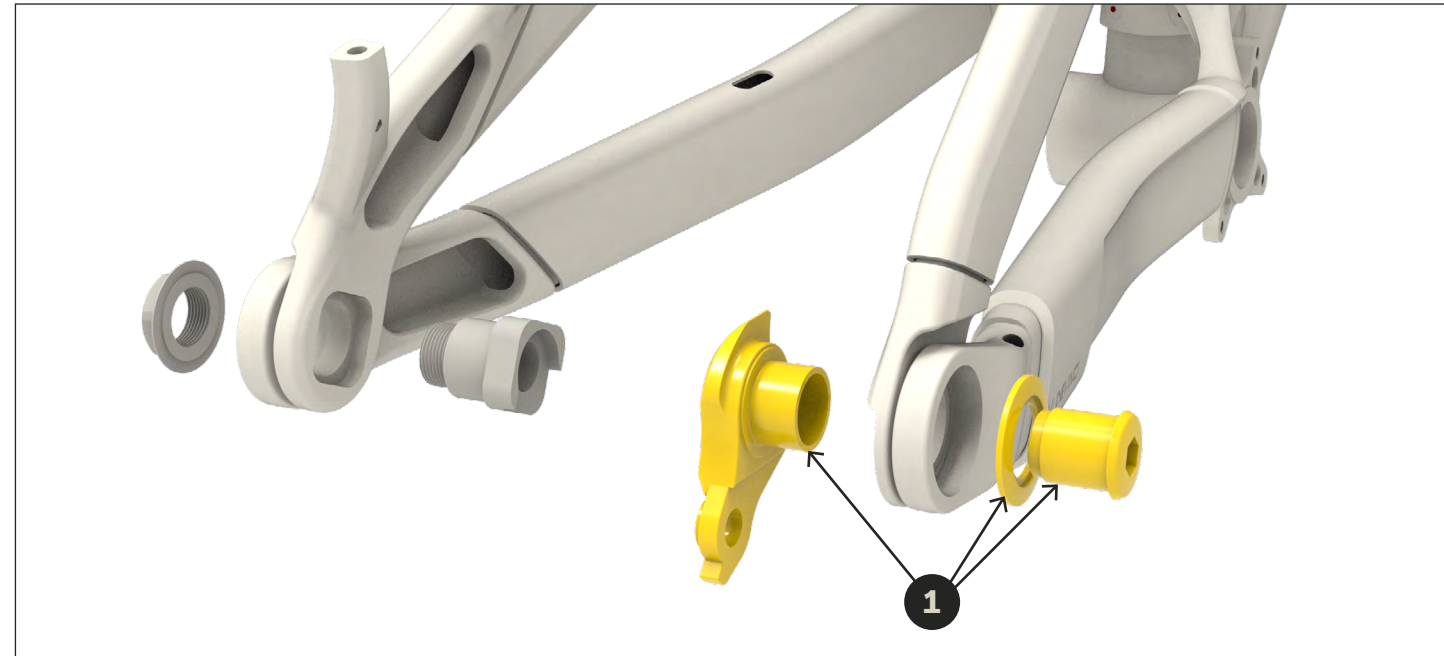

KFC06503 | REAR AXLE BOOST 148 12MM UDH

ITEMS	PART #	DESCRIPTION	QTY
2	MATAR23002	Rear axle for 148mm UDH	1

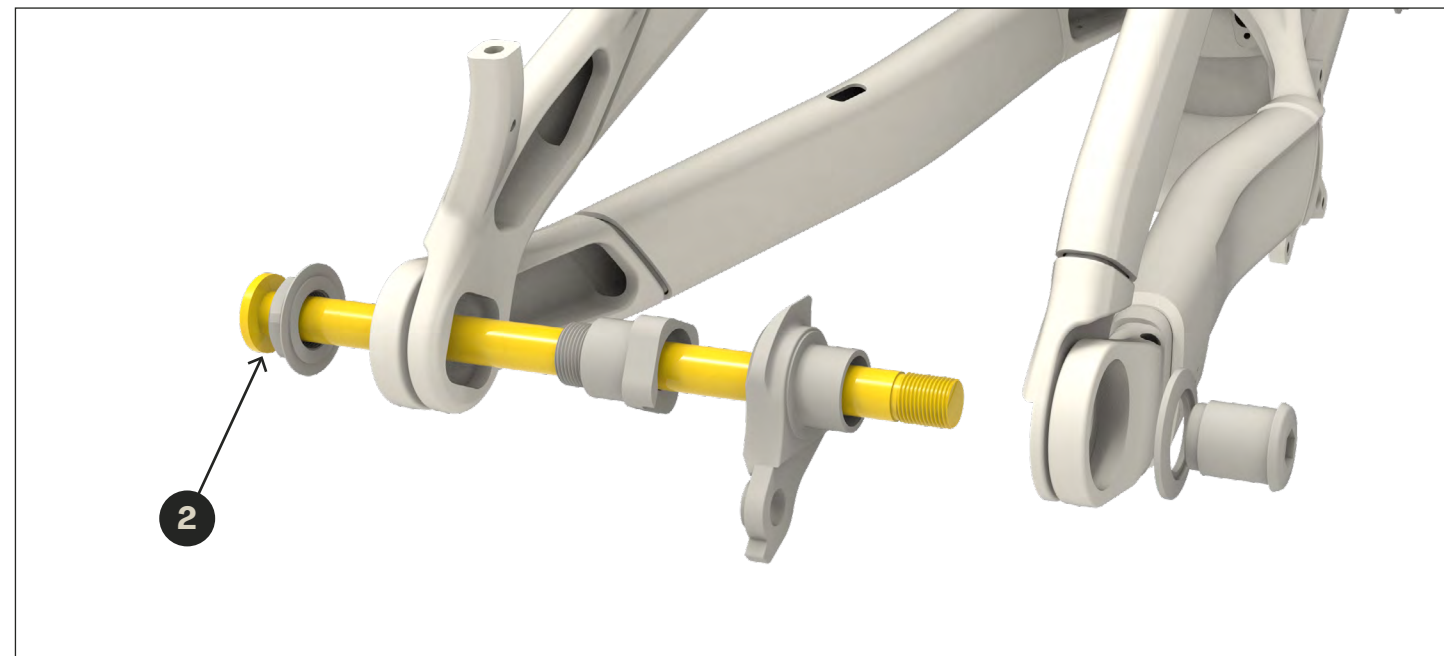

KFC09007 | TOOL BAG FOR SHED STORAGE



ITEMS	PART #	DESCRIPTION	QTY
1	MFP24031	Tool bag	1



KFC09008 | SHED SPACER

ITEMS	PART #	DESCRIPTION	QTY
1	MFP24026	Aluminium frame SHED spacer	1

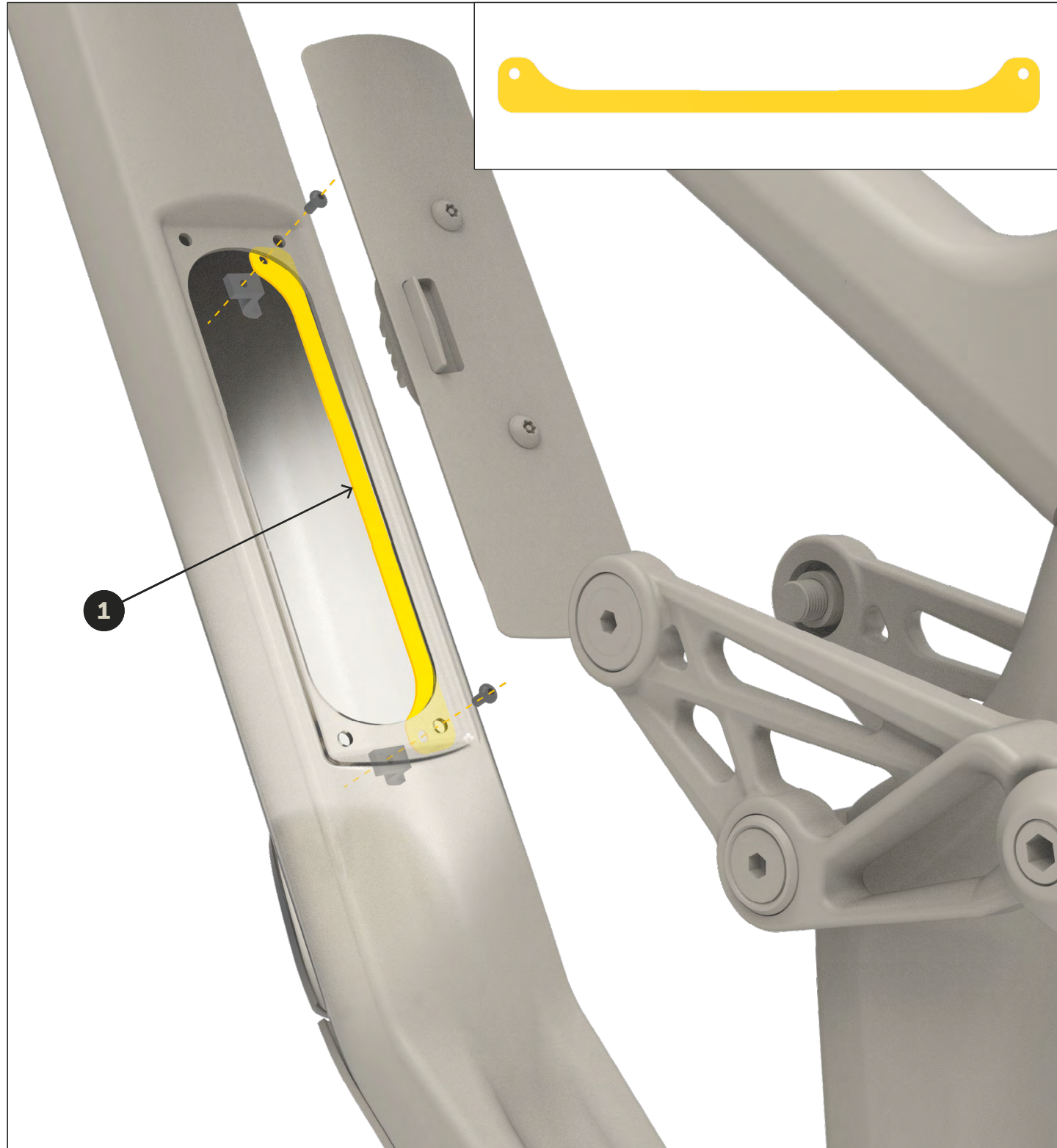

WARRANTY

WARRANTY PERIOD FROM Devinci CYCLES INC

The frames of cycles Devinci inc. are guaranteed against all manufacturing defects, for the periods specified below, as of the date of the initial purchase. During these specific periods, Devinci will replace or repair without charge, and at its discretion, the Devinci frames that display a manufacturing defect. The parts replaced or repaired in accordance with this warranty, will be covered for a period equal to the remaining portion of the warranty of the original equipment. Replacement parts are subject to availability. In certain cases, color and/or model may differ from the original parts.

BICYCLE FRAMES & WARRANTY PERIOD

Since 2006, all the frames bike model, including all mountain, freeride, downhill frames and dirt jump are guaranteed for life. Paint and decals for all models of frame:

- 1 year the pivots* for double suspension frames;
- 1 year the components assembled on Devinci frames are guaranteed by their respective manufacturers.

Please contact your authorized Devinci retailer. For more information regarding the applicable warranties.

*The pivots include the bearings, bolts and axles holding together the elements of the suspension of the rear triangle.

WARRANTY EXCLUSIONS

Each Devinci bicycle was conceived for a specific use. The operational life of a bicycle varies according to its construction, maintenance and the care provided. Intensive use or use with a heavy load, use during competitions or for activities other than those for which the bicycle was conceived, greatly diminish its operational life. Any of these conditions may lead to random failure. Abusive use will therefore cancel the warranty.

EXCHANGE POLICY IN CASE OF ACCIDENT

Devinci is aware that the purchase of a high performance bicycle is done with the heart. This is why our customer service applies an exchange policy at a low price to accommodate claims that would have been refused for one of the reasons mentioned in the section "warranty exclusions". This policy applies only to the initial buyer. Please contact your Devinci retailer for more information.

Limitation of liability: this is an integral warranty, complete and final, for Devinci frames. Devinci does not give authorization to any other person, including the authorized Devinci retailers, to assume or grant, expressly or implicitly, any or all addition(s) or extension(s) to the warranty specified herein. Any other obligation or responsibility expressed by any other person(s) and any demonstration or illustration of Devinci frames is in no way linked to Devinci and is furthermore excluded from this warranty.

Devinci assumes no liability in case of any property damage, moral or bodily injury to the user, the buyer or any other person(s), resulting from the use of a Devinci frame or one of its components.

Except as limited or expressly forbidden by law, regarding any other condition or guarantee, express or implied, based in law, established commercial customs and usage, including, but not limited to, guarantee of merchantability or adaptation to a specific end, Devinci declines any responsibility for any amount exceeding the actual purchase price of the bicycle nor for any particular, accessory or consecutive damages that may occur in connection with said bicycle.

With regard to the exercising of rights resulting from the present warranty, the buyer of a Devinci frame agrees to elect domicile in the judicial district of chicoutimi, in the province of quebec, canada, as an appropriate place for the hearing of all claims or legal proceedings.



THIS WARRANTY DOES NOT COVER :

- Regular maintenance (cleaning, lubrication or inspection);
- TranOptimum S or shipping charges incurred as a result of the execution of the warranty;
- Cost of labour related to the assembly, disassembly, repair or replacement parts;
- Devinci assumes no responsibility for any issues or damages arising from modifications that fall outside the original specification of the bicycle. For optimal performance and to maintain your warranty, it is essential to adhere to the factory-recommended specifications. Please refer to "FORK TRAVEL ALTERATIONS" section for specifics.
- Damages caused by normal wear and tear including damages caused by material fatigue.

THIS WARRANTY DOES NOT APPLY IF :

- The damages were caused by a fortuitous event;
- The bicycle was purchased from a retailer other than those authorized by Devinci;
- The bicycle was not entirely assembled by an authorized Devinci retailer;
- The bicycle was repaired by a person other than an authorized Devinci retailer;
- You are not the original owner of the bicycle;
- The instructions contained in the user's manual for all frames and the technical manual for frames with double suspension were not respected;
- The periodic inspection recommended in the user's manual for all frames and in the technical manual for the frames with double suspension was not carried out;
- Parts not supplied by Devinci with the bicycle or not indicated in the user's manual for all frames or the technical manual for the frames with double suspension were used;
- The bike paint is damaged as a result of an adhesive frame protector installation;
- The bicycle was used for an activity other than those for which it was conceived;
- The bicycle and/or its components were subject to abusive use, negligence, abnormal and/or excessive use or was implicated in an accident;
- The frame is too small for you;
- The frame and/or its components were modified (ex: polishing, structural or mechanical modification or addition, stripping, sanding, strain hardening, shot peening);
- You continued to use your bicycle while it was damaged.



Head Office

1555 Manic
Chicoutimi (Quebec) Canada
G7K 1G8

www.Devinci.com
